



Before you use this machine, please read this specification carefully.



**480DS 6508D**

**Digital-displayed Paper Cutting Machine**

## **Operation Instructions**

- If there is any improvement on the product, please firmly comply with the definite object.

**Repair warranty**

1. The guarantee period of paper-cutting machine is one year. You should register in maintenance station within one month after you buy the machine, in order to establish maintenance file.
2. Maintenance service scope:
  - ① Supply the service of installation, adjustment, operation, training, periodic maintenance, elimination of error in normal operation, and repair.
  - ② Supply to change parts damaged in normal operation; maintain motor and circuit for one year; knife shim and blade belong to expendable supplies, so they are excluded from the maintenance scope.
3. Maintenance should be undertaken by the local sales agency.
4. We won't undertake the maintenance and accessories diversion fees caused by conditions below:
  - ① Damage caused by accident, wrong operation or intent disassembling.
  - ② Repaired by stations not authorized by our company, or use dependable materials and accessories not required by our company.
  - ③ The customer doesn't register in the maintenance station within one month after he buys the machine.
  - ④ The machine is damaged because of oil lack, oil in or water inflow.

**Contents****Foreword****Safety cautions****Chapter I**

|                               |   |
|-------------------------------|---|
| 1. Open the machine and check | 1 |
| 2. Settlement of the machine  | 1 |
| 3. Operating environment      | 1 |
| 4. Special suggestions        | 1 |

**Chapter II****Brief introduction of the paper-cutting machine**

|   |   |
|---|---|
| 1. Parts description of the paper-cutting machine | 2 |
| 2. Principal technical parameter                  | 2 |
| 3. Performance features                           | 3 |
| 4. Operating panel                                | 3 |

**Chapter III****Basic operation**

|                      |   |
|----------------------|---|
| 1. Start the machine | 4 |
| 2. Push paper        | 4 |
| 3. Cut paper         | 4 |

**Basic adjustment**

|                                   |   |
|-----------------------------------|---|
| 1. Dimension check and adjustment | 5 |
| 2. Cutting power adjustment       | 5 |
| 3. Knife blade change             | 5 |
| 4. Cutting stick adjustment       | 6 |

**Chapter IV****Lubrication and maintenance**

|                    |   |
|--------------------|---|
| 1. Lubrication     | 7 |
| 2. Maintenance     | 7 |
| 3. Attached figure | 7 |

**Chapter V**

|                              |   |
|------------------------------|---|
| Common error and elimination | 8 |
|------------------------------|---|

**Chapter VI**

|                      |   |
|----------------------|---|
| Maintenance warrants | 9 |
|----------------------|---|

Thank you for your choice of our Digital-display Paper Cutting Machine series. We will provide you with good quality and reliable post-sale service. On the basis of original products, our research and develop engineers combined advantages of products at home and abroad, and finally developed new model of Digital-display Paper Cutting Machine. It owes high technology, precise construction designation, and elegant appearance, with the security control part and cutting precision improved. It can be broadly used in printing centers and offices. It is the most ideal cutting machine which well complies with office automation system.



Children must not operate this machine.



Do not reach beneath the blade



Do not extract or transport the blade without protection



Do not cut hard material or materias which may splinter!

**Note:** In order to have more usage information of Numerical-controlled Paper Cutting Machine, you have to read this specification carefully first. This will help you improve your working efficiency, realize the machine's property, have the best cutting effects. This will also be good for the maintenance of the machine, and can prolong service life of the machine.

### Common error and elimination

| Error  | Phenomena   | Elimination method  |
|--|---|---|
| No power source display                                  | Indicating light is off   | 1. Check the power source plug<br>2. Check main switch<br>3. The power source wire is bad   |
| Incomplete cutting                                       | Paper can't be cut completely   | 1. The blade abrades badly<br>2. The knife position is too high. Revolve the screw of adjusting blade depth on the blade carrier downward to have the knife position lower. |
| Too deep cutting   | Slash on the knife strip it too deep  | The knife position is too low. Revolve the screw of adjusting blade depth on the blade carrier on the knife upward to have the knife position higher.                       |
| Dull blade   | Paper can't be cut completely or cutting becomes difficult                                    | 1. Sharpen the blade: Use whetstone to sharpen or ask professional factory to do sharpening.<br>2. Change a new blade   |
| Capacitor of electrical motor damaged                    | The knife work up and down slowly or powerlessly  | Change Capacitor  |
| Irregular paper-cutting or too big difference            | The cut paper has one side wide and the other side narrow, or has big deviation on dimensions | Loose tighten screw, and use a ruler to adjust the angle between measuring scale and paper-pushing plate  |
| The knife can't reset or works up and down continuously  | The button is invalid. The blade works up and down without stopping                           | 1. The sensor is displaced or damaged.<br>2. Circuit main panel is damaged  |
| The window can't display or display wrong or can't check | Normal buttons of power source are invalid  | Check display board, main board of the electrical equipment, and circuit parts  |



## Lubrication and Maintenance

### 1.Lubrication

Every three month, you should open the brace plate of the machine, check and clean, tighten parts, and use lubricating oil to rolling parts. When you do lubrication, be careful to avoid lubricating oil dripping on the wires or electrical parts. The speed reduction box needs to be cleaned and lubricated once a year.

### 2.Maintenance

1)When the machine is running, foreign objects are forbidden to put on the machine, because if hard objects come under the blade, the blade will be damaged. There should be no staple pin in the book, which is coming to the cutting area, to avoid damaging the blade.

2)After everyday work, you should wipe the machine, remove junk, wax the blade to protect it, and cut the power.

### 3.Attached figure

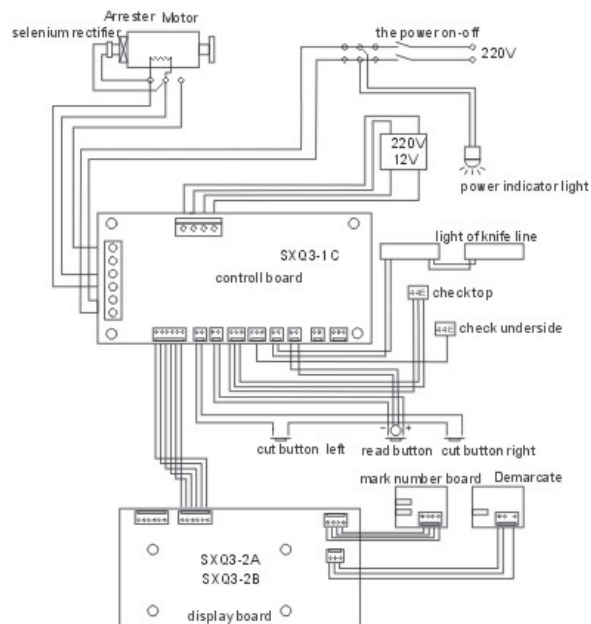

650 Digital cutting machine circuit line chart

## Safety Cautions

According to relevant standards, to avoid accident and accidental injury, only professional operators are allowed to use this machine (children or non-professional operators are forbidden to operate). When you use or maintain these machines, please pay high attention to safety cautions below:

### ● Settlement position

Please connect with the power source correctly in accordance with the specification. The power source should be steady AC220V.50Hz.2KW, and the machine will run irregularly if the voltage is too high or too low. We suggest you use alternating current (AC) power source with steady voltage to improve your working efficiency.

### ● Ground connection

For safety you should use electric supply socket with ground wire connected.

### ● Supercharge

Please don't connect many electrical products on one electric supply socket, because supercharge may cause a fire or an electric shock.

### ● Cleanness

Before you clean or maintain the machines, you must cut the electric source and pull out the electric supply socket.

## 1. Open the machine and check

When you open the package of the machine, firstly you should check the machine and relevant accessories. Please contact the seller or our company if there is any damage or shortage.

|                   |                                  |                               |
|-------------------|----------------------------------|-------------------------------|
| Main unit one set | Machine chassis one set          | Specification one piece       |
| Tooling one set   | Rubber under chassis four pieces | Certificate one piece         |
| Stick one piece   | Screw stem two pieces            | Maintenance warrant one piece |

## 2. Settlement of the machine

- Open the wooden crate, take out the machine casing, and discharge four M8 screws on the base plate of the main machine;
- The machine casing needs to assembly, and the screws should be fixed firmly;
- The main unit should be put on the machine casing correctly;
- Check all parts of the machine, and clean them;
- Turn on the power to electrify to test running.

## 3. Operating environment

- The machine should be placed in clean working environment, without direct contact with sunlight and wind;
- Temperature of the operating environment: 10-30°C, cannot higher than 32°C;
- Humidity level of the operating environment: 50-80%;
- Working power source of the machine: 220V±10%; 50HZ; 4KW;
- Connect the ground wire correctly.

## 4. Special suggestions

- Remember, only one professional operator is allowed to work on the machine;
- When you cut, you should operate buttons by both of your hands;
- Please don't disassemble the safety covering;
- When you put your hands or other things into the cutting area, you must cut the power first;
- When you change knife blades, you should firmly comply with the blade changing instruction;
- You are not allowed to re-equip the inner construction and circuit of the machine by yourself.

- When you install the blade, you should loose the screws of adjusting blade depth on the blade carrier, then screw up the screw stems, and fix up the blade carrier. After that, make screw strip be fasten and fix up one by one, then adjust according to cutting depth adjustment method;
  - Blade sharpening needs to be done in a professional factory, so that to ensure the quality.
- ※ **Note: To avoid any injury, you must be the most careful when you change the blade.**

## 4. Cutting stick adjustment

- One cutting stick can be used for 8 times;
- When slash on the stick is too deep, you should adjust or change knife strip;
- Cutting stick can be took out by screw, and should be assembled onto the cutting desk flatly when it needs to be set back;
- Cutting stick should lean to the left side, then re-push the front brace plate;

※ **Note: When cutting stick is being changed, the blade itself also needs to be adjusted. If the blade cuts too deep, the cutting stick will be damaged easily, and also the blade will abrade rapidly.**



## Basic adjustment

### 1.Dimension check and adjustment

- Cut the electricity power;
- Check whether there is any foreign matter on the guiding rod;
- Pull out the front covering strip, and check stepping motor, to see whether the synchronous pulley and synchronous belt are fixed normal;
- Adjust the support chip on the screw, and you can move it back and forth until digital display dimension matches measuring scale dimension, then lock the retaining screw firmly.

### 2.Cutting power adjustment

- Cut the electricity power;
- Disassemble retaining screws on both sides of the upper cover, and then take the upper cover away;
- Loose seven M6 fasten screws on the blade which is on blade carrier, and adjust screws of adjusting blade depth on blade carrier, until the blade cuts into the stick about 0.3-0.5 mm;
- Tighten up fasten screws on blade carrier, put on the upper cover, then fix up;
- Choose one piece of paper to have a trial cut. If it cannot be cut completely, you can readjust according to the processes above.

### 3.Knife blade change

※Note: Dull blade can't cut paper correctly. Also, blade will become dull if it always cuts thick paper or pasteboard. If cutting quality and accuracy can't meet required standard, the blade needs to be changed. Your work will go smoothly if you always have one replacement on hand. When you need to change blade, you must operate according to the steps of blade change instruction.

- Open the upper cover;
- Loose the notched fasten screw on the blade carrier, revolve the two screw stems clockwise, and then fix up and lock firmly;
- Take away other fasten screws on the blade carrier;
- Revolve the two screw stems anticlockwise 180°, then take out the blade. Please wear gloves or use cotton cloth to wrap the blade to avoid scratch;

## 1. Brief introduction of the paper-cutting machine

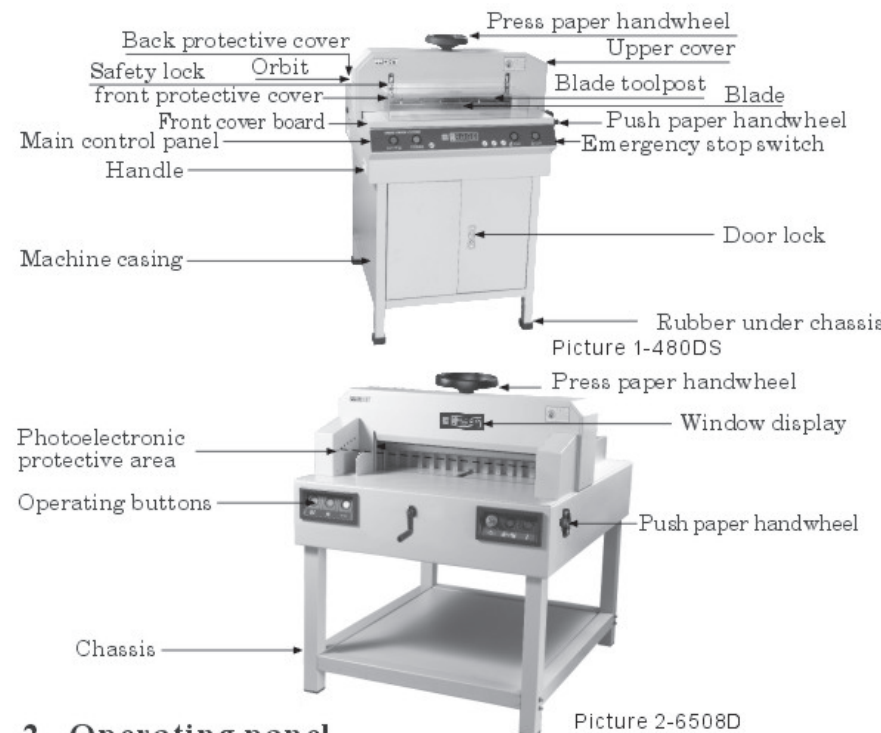

## 2. Operating panel

Picture 3-480DS

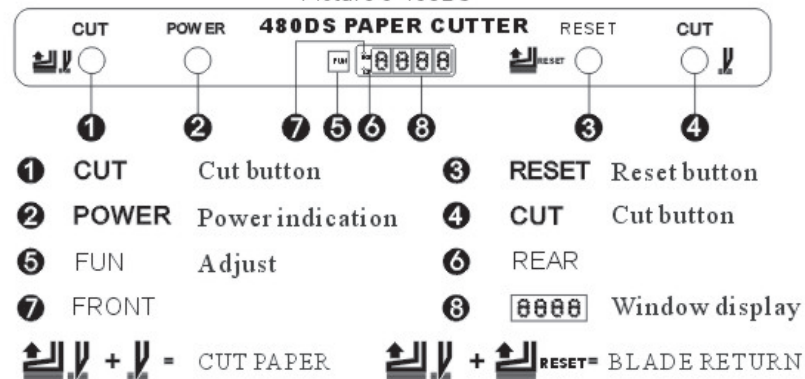



+ = CUT PAPER

+ = BLADE RETURN

= RESET

Picture 4-6508D

### 3. Main technical data

| Specification \ Model       | 480DS          | 6508D           |
|-----------------------------|----------------|-----------------|
| Cutting width(mm)           | 480            | 650             |
| Cutting thickness           | 50             | 80              |
| Paper pressing structure    | Manual         | Manual          |
| Paper pushing mode          | Manual         | Manual          |
| Safety protection           | Yes            | Yes             |
| Power supply                | 950W           | 1.2KW           |
| Machine Measurement (H*D*W) | 1100X820X740mm | 1150X1050X950mm |
| Net weight                  | 123kg          | 260kg           |

### 4. Characteristics of digital cutting machine:

- Whole machine stander manufactured in good quality;
- Manual spindle clamp with hand wheel;
- Precise digital-displayed circuit design, double orbit for pushing paper;
- Designed with CE standard, front& back protection cover conform to safe system;
- Spin cutter with depth curve technology device;
- Inclined cutting technology;
- Rapid steel blade is sharp and durable;
- Opitical cutting line;
- Fashionable appearance design with patented.

## Basic operation

Before operating, please review contents described before carefully. Then you can do operations below.

### 1.Start the machine

- Insert the power plug into AC220V/50HZ 4KW socket.
- Turn the protective switch to 'On' position. Rotate on emergency switch, the liquid crystal displays and indicative wiring of knife position is lighting, that means electricity connection is normal.

### 2.Paper Pushing

- Open the front protective cover, push paper or book to the left side aligned with the measuring scale.
  - Rotate the hand wheel of pushing paper to the required cutting size, the display size number comply with scale mark.
  - If the cutting size does not comply with measuring scale marks, please rotate handwheel of pushing paper or adjust according to the method in diameter check and adjustment
- ※ **Note: Press FUN button , hold it in five seconds until displaying mm /inch mode**

### 3.Cutting paper

- 1.Please lay down front protective cover after cutting dimension is properly adjusted.(Only for 480DS)
2. Turn press paper handwheel. Tighten cutting material.
- 3.LED turn red after pressing reset button. Then the light for indicating knife position is on.
- 4.Follow drawing 3 before cutting(Only for 480DS)
5. Follow drawing 4 before cutting(Only for 6508D)
- 6.If it is found that the last piece of paper is not cut apart, please adjust according to the method of 'Cutting Knife Adjustment'.

※ **Note: If the front protective cover has not been put down completely, cut buttons can not be operated.**